

OMNIDEKA

HIGH-LEVEL AUTOMATIC BIN LIFT

The OmniDEKA comes with the expected robust build, safe operation and efficiency synonymous with the Terberg brand to provide the market with the best automatic high-level bin lift solution available today.



REASONS TO CHOOSE THE OMNIDEKA:

- OmniDEKA provides flexible mounting heights ranging from 1150mm to 1675mm to suit a variety of applications.
- OmniDEKA provides ultra-strong lifting power for two-wheeled bins of 170kg and up to 500kg for four-wheeled bins
- OmniDEKA's modern design features large side windows for optimal visibility and improved safety.
- Amazingly light, the OmniDEKA weighs just 650kg (without DIN pick up arms)
- Two-wheeled EN840-1 containers cycle time is 6–7 seconds, while OmniDEKA handles four-wheeled EN840-2 & 3 containers in 10–12 seconds.
- A short rear overhang of only 800mm, extending to 1130mm when safety arms are deployed.
- Superbly steep container discharge angle of 46 degrees to reduce the risk of non-emptying bins
- Universal mounting according to EN 1501-1
- 6 percent more room on the footboards
- The OmniDEKA dynamic split catcher bar automatically operates as needed and returns to its original position after container discharge.
- The user friendly folding safety arms conform to EN1501-1 standard and provides guarding against entry into the functional working space during bin lift operation
- Ground clearance of ± 450 mm
- The lifting chair stores kinetic energy during upward movement, allowing gravity-powered, quiet returns that save energy and minimise wear.
- Single point greasing
- Optional service modem possible
- Built for weighing accuracy: smooth operation reduces bin bounce, and a vertical lift creates a clear 'window' for easy data recording.
- Featuring BCCU, a cleaning mode switch, and two emergency stop buttons per side as standard
- The Bin Compaction Control Upgrade (BCCU) automatically stops movement if cycle start sensors or container security are triggered, and cleaning mode enables safe container cleaning.
- Safeguard functionality – The safeguard system protects operators, and others, against serious injury if they go too near to parts that can move automatically. The safeguard stops the automatic cycle and prevents the start of one.

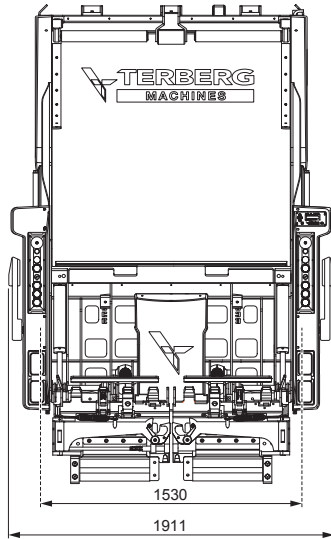

A	B
1200	528
1300	528
1400	528
1500	528
1600	578

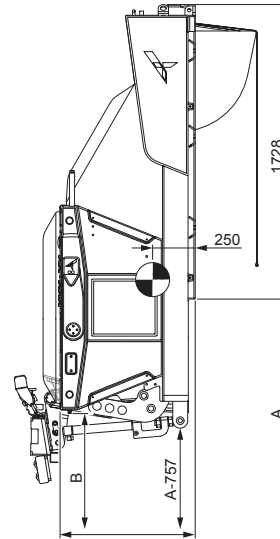

TECHNICAL SPECIFICATIONS



EN 840-1 | 80-360L



EN 840-2 | 500-1280 L



EN 840-3 | 770-1100 L

Chair configuration

Single Man Trade (SMT)

Pick up arms for bins according to EN 840-2/-3 with trunnions

Rear Protective Device (RPD)

4-wheeled recognition

Bin Compaction Control Upgrade (BCCU)

Diagnostic display

Shaking

Terberg Weighing and RFID preparation

CleanOpen CANbus output

Packer Cycle Delay Control (PCDC)

Lifting capacity

Bin lift weight

Power source

Electrical connections

Hydraulic connections

Hydraulic specifications

Cycle time

Noise level

Safety and norm compliance

Split twin chairs

Standard

Option

Standard

Standard

Standard

Standard

Standard

Option

Option

Standard

170kg (split) / 700kg (linked)

Ca. 650kg

Hydraulic / electric

16-pin / 24v

Quick release couplings (DIN 2353, NW13, NW20)

Ideal 40 ltr./min., maximum 60 ltr./min., 180bar

2 wheel secs 6- 7 (= dwell 0.5-1.5)/

4 wheel ±10-12 secs

< 61 dB(A)

CE machinery directive certification EN 1501-1 & EN 1505-5



TERBERG ENVIRONMENTAL

Newtonstraat 2, 3401JA. IJsselstein, The Netherlands

T +44 (0)1925 458 500, E info@terbergenvironmental.com, I www.terbergenvironmental.com

Terberg Environmental reserve the right to change the specification or design of our equipment at any time without prior notification.